

# SIEMENS

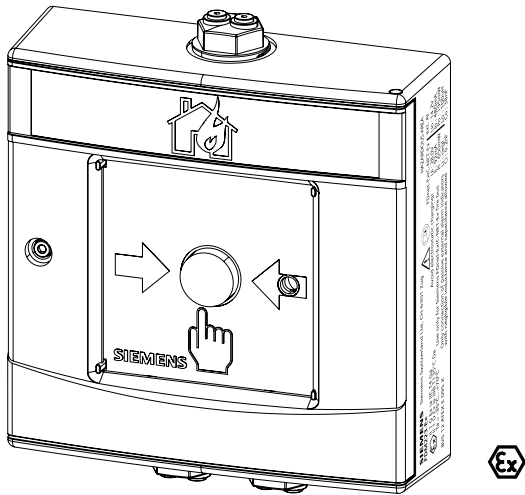

## FDM223-Ex

## Manual call point

## Technical Manual

## Legal notice

Technical specifications and availability subject to change without notice.

© Siemens Switzerland Ltd, 2012

Transmittal, reproduction, dissemination and/or editing of this document as well as utilization of its contents and communication thereof to others without express authorization are prohibited. Offenders will be held liable for payment of damages. All rights created by patent grant or registration of a utility model or design patent are reserved.

Issued by:

Siemens Switzerland Ltd.

Building Technologies Division

International Headquarters

Gubelstrasse 22

CH-6301 Zug

Tel. +41 41 724-2424

[www.siemens.com/buildingtechnologies](http://www.siemens.com/buildingtechnologies)

Edition: 2015-02-02

Document ID: A6V10349616\_g\_en\_--

# Table of contents

<b>1</b>	<b>About this document</b> .....	<b>5</b>
1.1	Applicable documents.....	8
1.2	Download center.....	9
1.3	Technical terms, abbreviations, and formula symbols.....	10
1.4	Revision history .....	11
<b>2</b>	<b>Safety</b> .....	<b>12</b>
2.1	Safety instructions .....	12
2.2	Safety regulations for the method of operation .....	13
2.3	Standards and directives complied with .....	16
2.4	Release Notes.....	16
<b>3</b>	<b>Structure and function</b> .....	<b>17</b>
3.1	Overview .....	17
3.1.1	Details for ordering.....	17
3.1.2	Reference to technical manual .....	17
3.1.3	Product version ES .....	18
3.2	Setup.....	19
3.2.1	Manual call point FDM223-Ex .....	19
3.2.2	Connections.....	20
3.2.3	Indication elements.....	20
3.3	Function .....	21
3.3.1	Danger levels.....	21
3.3.2	Internal alarm indicator.....	21
3.3.3	Test mode .....	21
3.3.4	Diagnosis levels.....	21
3.3.5	Behavior in degraded mode .....	22
3.3.6	Line tester.....	22
3.4	Accessories.....	23
3.4.1	Glass insert DMZ1196-AC .....	23
3.4.2	Protective cover DMZ1197-AC.....	23
3.4.3	Cable gripper (2-hole).....	23
3.4.4	M20 x 1.5 metal cable gland .....	23
3.4.5	Seal DMZ1197-AD.....	24
3.4.6	Line adapter (Ex) FDCL221-Ex .....	24
<b>4</b>	<b>Planning</b> .....	<b>25</b>
4.1	Compatibility.....	25
4.2	Fields of application.....	25
4.3	Mounting site.....	25
<b>5</b>	<b>Mounting/Installation</b> .....	<b>26</b>
5.1	Preparation.....	27
5.2	Mounting .....	28
5.3	Electrical connection.....	29
5.4	Installing the protective cover.....	32

<b>6</b>	<b>Commissioning</b> .....	<b>33</b>
6.1	Localization and device testing .....	33
6.2	Checking function.....	34
<b>7</b>	<b>Maintenance / troubleshooting</b> .....	<b>35</b>
7.1	Resetting after an alarm .....	35
7.2	Status query .....	35
7.3	Performance check.....	35
7.4	Replacing the glass insert.....	36
<b>8</b>	<b>Specifications</b> .....	<b>37</b>
8.1	Technical data.....	37
8.2	Dimensions .....	39
8.3	Master gauge for recesses .....	39
8.4	Environmental compatibility and disposal .....	40
	<b>Glossary</b> .....	<b>41</b>
	<b>Index</b> .....	<b>42</b>

# 1 About this document

## Retention and availability

	<b>NOTICE</b>
	<p><b>Missing information</b></p> <p>Damage due to misuse</p> <ul style="list-style-type: none"> <li>This document must be available in a usable format throughout the entire life cycle of the product. Keep the document for reference and ensure that it can be accessed by target groups.</li> </ul>

Should you require another copy of this document, please contact the Customer Support Center, phone +49 89 9221-8000.

## Goal and purpose

This document contains all information on the manual call point FDM223-Ex. Following the instructions consistently will ensure that the product can be used safely and without any problems.

This document is aimed at users who are planning, installing, commissioning, operating, and maintaining a fire detection installation FS20/FS720 or SIGMASYS with a line card (FDnet/C-NET) with addressed detector lines within the scope of Directive 94/9/EC (ATEX directive) or IECEx.

General knowledge about the structure and function of fire detection installations FS20/FS720 is required in order to understand the information.

	<b>WARNING</b>
	<p><b>Document A6V10324618 is an integral part of this document. You must observe the information in both this document and document A6V10324618!</b></p>

Before installing the device, you must make yourself familiar with the content of document A6V10324618 'Planning, Mounting/Installation, Commissioning, Maintenance of fire detection installations with addressed detector lines in potentially explosive atmospheres'. You can download the current version of the document from the Internet, at the address <http://siemens.com/bt/download>.

## Device labeling

Device type	FDM223-Ex
Manufacturer	Siemens Switzerland Ltd. Infrastructure & Cities Sector Building Technologies Division International Headquarters Gubelstrasse 22 CH-6301 Zug Tel. +41 41 724-2424 www.siemens.com/buildingtechnologies
Year of construction	2014 or later
IECEx scheme	Ex ia IIC T4 Ga, Ta = -35...70 °C Ex ia IIIB T135 °C Da , Ta = -35...70 °C
Directive 94/9/EC (ATEX Directive)	II 1 G Ex ia IIC T4 Ga, Ta = -35...70 °C II 1 D Ex ia IIIB T135 °C Da, Ta = -35...70 °C

When used in atmospheres at risk of gas explosion:

The manual call point FDM223-Ex must be protected against electrostatic charging, along with all its accessory parts.

### Intended use

The manual call point FDM223-Ex may only be used as follows:

- On an FDnet-Ex/C-NET-Ex detector line in a fire detection installation FS20/FS720
- On the detector line the manual call point FDM223-Ex must be installed downstream of a line adapter (Ex) approved in accordance with national and international regulations. For the FDnet-Ex/C-NET-Ex detector line, this is line adapter (Ex) FDCL221-Ex.



Please note the documents listed in the chapter 'Applicable documents [→ 8]'.  

---

## Target groups

The information in this document is intended for the following target groups:

Target group	Activity	Qualification
Product Manager	<ul style="list-style-type: none"> <li>● Is responsible for information passing between the manufacturer and regional company.</li> <li>● Coordinates the flow of information between the individual groups of people involved in a project.</li> </ul>	<ul style="list-style-type: none"> <li>● Has obtained suitable specialist training for the function and for the products.</li> <li>● Has attended the training courses for Product Managers.</li> </ul>
Project Manager	<ul style="list-style-type: none"> <li>● Coordinates the deployment of all persons and resources involved in the project according to schedule.</li> <li>● Provides the information required to run the project.</li> </ul>	<ul style="list-style-type: none"> <li>● Has obtained suitable specialist training for the function and for the products.</li> <li>● Has attended the training courses for Project Managers.</li> </ul>
Project engineer	<ul style="list-style-type: none"> <li>● Sets parameters for product depending on specific national and/or customer requirements.</li> <li>● Checks operability and approves the product for commissioning at the place of installation.</li> <li>● Is responsible for trouble-shooting.</li> </ul>	<ul style="list-style-type: none"> <li>● Has obtained suitable specialist training for the function and for the products.</li> <li>● Has attended the training courses for Product Engineer.</li> </ul>
Installation personnel	<ul style="list-style-type: none"> <li>● Assembles and installs the product components at the place of installation.</li> <li>● Carries out a performance check following installation.</li> </ul>	<ul style="list-style-type: none"> <li>● Has received specialist training in the area of building installation technology or electrical installations.</li> </ul>
Maintenance personnel	<ul style="list-style-type: none"> <li>● Carries out all maintenance work.</li> <li>● Checks that the products are in perfect working order.</li> <li>● Searches for and corrects malfunctions.</li> </ul>	<ul style="list-style-type: none"> <li>● Has obtained suitable specialist training for the function and for the products.</li> </ul>

There are various tasks that may only be performed by qualified persons in accordance with the national implementation of Directive 2009/104/EC (e.g. in Germany: Section 2 (7) of the Ordinance on Industrial Safety and Health (BetrSichV)).

## Source language and reference document

- The source/original language of this document is German (de).
- The reference version of this document is the international version in English. The international version is not localized.

## Document identification

The document ID is structured as follows:

ID code	Examples
ID_ModificationIndex_Language_COUNTRY -- = multilingual or international	A6V10215123_a_de_DE A6V10215123_a_en-- A6V10315123_a----

## Date format

The date format in the document corresponds to the recommendation of international standard ISO 8601 (format YYYY-MM-DD).

## Conventions for text marking

### Markups

Special markups are shown in this document as follows:

>	Requirement for a behavior instruction
1. 2.	Behavior instruction with at least two operation sequences
–	Version, option, or detailed information for a behavior instruction
⇒	Intermediate result of a behavior instruction
⇒	End result of a behavior instruction
●	Numbered lists and behavior instructions with an operation sequence
[→ X]	Reference to a page number
'Text'	Quotation, reproduced identically
<Key>	Identification of keys

### Supplementary information and tips



The 'i' symbol identifies supplementary information and tips for an easier way of working.

## 1.1 Applicable documents

Document ID	Title
008250	Technical Manual Line tester FDUL221
008331	List of compatibility (for 'Sinteso™' product line)
009052	FS20 Fire detection system - Commissioning, Maintenance, Troubleshooting
A6V10210416	FS720 Fire detection system - Commissioning, Maintenance, Troubleshooting
A6V10229261	List of compatibility (for 'Cerberus™ PRO' product line)
A6V10260486	Installation Alarm indicators, adapter frame, surface-mounted housing, indicator housing, incl. washer FDAI92EX, FDAI93EX, AI330, DCA1191, DJZ1193
A6V10324618	Planning, Mounting/Installation, Commissioning, Maintenance of fire detection installations with addressed detector lines in potentially explosive atmospheres
A6V10333771	Technical Manual Line adapter (Ex) FDCL221-Ex
A6V10349347	Data sheet Manual call point FDM223-Ex
A6V10349619	Installation Manual call point FDM223-Ex

Please also observe the documentation for your fire detection system.

## 1.2 Download center

You can download various types of documents, such as data sheets, installation instructions, and license texts via the following Internet address:

<http://siemens.com/bt/download>

- Enter the document ID in the 'Find by keyword' input box.



---

You will also find information about search variants and links to mobile applications (apps) for various systems on the home page.

---

## 1.3 Technical terms, abbreviations, and formula symbols

Term	Explanation
AI	Alarm indicator
ASA	Advanced Signal Analysis
BetrSichV	Betriebssicherheitsverordnung, national implementation in the Federal Republic of Germany of Directive 2009/104/EC on the use of work equipment
ES	Product version
FDnet/C-NET	Addressed detector line
FDnet-Ex/C-NET-Ex	Addressed detector line in a potentially explosive atmosphere downstream of a line adapter (Ex) FDCL221-Ex
LED	Light-emitting diode

Symbol	Meaning
$C_0$	Maximum external capacity
$C_C$	Maximum permissible cable capacitance
$C_i$	Maximum internal capacity
$I_0$	Maximum output current
$I_i$	Maximum input current
$L_0$	Maximum external inductivity
$L_C$	Maximum permissible cable inductance
$L_i$	Maximum internal inductivity
$P_0$	Maximum output power
$P_i$	Maximum input power
$R_C$	Resistance of the connection cable
$T_a$	Ambient temperature in a potentially explosive atmosphere
$U_i$	Maximum input voltage
$U_m$	Maximum r.m.s. value of the alternating voltage. Maximum permissible voltage of an associated item of electrical equipment without canceling the energy limitation.
$U_0$	Maximum output voltage

You will find more technical terms in the glossary at the end of this document.



The symbols used correspond to the EN 60079-11 standard.

## 1.4 Revision history

The reference document's version applies to all languages into which the reference document is translated.



The first edition of a language version or a country variant may, for example, be version 'd' instead of 'a' if the reference document is already this version.

The table below shows this document's revision history:

Modification index	Edition date	Brief description
h	2015-02-02	Table listing published language versions corrected; IP protection category amended in 'Technical data' chapter; seal DMZ1197-AD added in 'Accessories' chapter; editorial changes
g	2014-07-22	Editorial changes
f	2014-05-23	Editorial changes; 'Download center' chapter added; reference to data sheet added; adhesive label 'Avoid electrostatic charging' removed; connection terminal in the housing and as accessory part removed
e	2013-07-31	Editorial changes
d	2013-04-30	Seal DMZ1197-AD and cable gripper (1-hole) removed; editorial changes.
c	2012-08-31	Notice of danger due to electrostatic charging changed.
b	2012-08-24	Editorial changes
a	2012-06-15	First edition



The table below shows the published language versions with the corresponding modification index:

Modification index	en_--	de_--	fr_--	it_--	es_--
h	X	X	X	X	X
g	X	X	X	X	X
f	-	X	-	-	-
e	X	X	-	-	-
d	-	X	-	-	-
c	-	X	-	-	-
b	-	X	-	-	-
a	-	X	-	-	-

X = published

- = no publication with this modification index

## 2 Safety

	 <b>WARNING</b>
	<p><b>Contradictory safety instructions</b></p> <p>Risk of explosion caused by disregarding safety instructions</p> <ul style="list-style-type: none"> <li>Should safety instructions relating to explosion protection contradict other safety instructions, please observe the safety instructions relating to explosion protection.</li> </ul>

### 2.1 Safety instructions

The safety notices must be observed in order to protect people and property.

The safety notices in this document contain the following elements:

- Symbol for danger
- Signal word
- Nature and origin of the danger
- Consequences if the danger occurs
- Measures or prohibitions for danger avoidance

#### Symbol for danger



This is the symbol for danger. It warns of **risks of injury**.  
Follow all measures identified by this symbol to avoid injury or death.

#### Additional danger symbols

These symbols indicate general dangers, the type of danger or possible consequences, measures and prohibitions, examples of which are shown in the following table:



General danger



Explosive atmosphere



Voltage/electric shock



Laser light



Battery



Heat

## Signal word

The signal word classifies the danger as defined in the following table:

Signal word	Danger level
<b>DANGER</b>	<b>DANGER</b> identifies a dangerous situation, which <b>will result directly in death or serious injury</b> if you do not avoid this situation.
<b>WARNING</b>	<b>WARNING</b> identifies a dangerous situation, which <b>may result in death or serious injury</b> if you do not avoid this situation.
<b>CAUTION</b>	<b>CAUTION</b> identifies a dangerous situation, which <b>could result in slight to moderately serious injury</b> if you do not avoid this situation.
<i>NOTICE</i>	<i>NOTICE</i> identifies possible damage to property that may result from non-observance.

## How risk of injury is presented

Information about the risk of injury is shown as follows:

	<b>▲ WARNING</b>
	<b>Nature and origin of the danger</b> Consequences if the danger occurs <ul style="list-style-type: none"> <li>• Measures / prohibitions for danger avoidance</li> </ul>

## How possible damage to property is presented

Information about possible damage to property is shown as follows:

	<b>NOTICE</b>
	<b>Nature and origin of the danger</b> Consequences if the danger occurs <ul style="list-style-type: none"> <li>• Measures / prohibitions for danger avoidance</li> </ul>

## 2.2 Safety regulations for the method of operation

### National standards, regulations and legislation

Siemens products are developed and produced in compliance with the relevant European and international safety standards. Should additional national or local safety standards or legislation concerning the planning, mounting, installation, operation or disposal of the product apply at the place of operation, then these must also be taken into account together with the safety regulations in the product documentation.

## Electrical installations

	<b>⚠ WARNING</b>
	<p><b>Electrical voltage</b> Electric shock</p> <ul style="list-style-type: none"> <li>• Work on electrical installations may only be carried out by qualified electricians or by instructed persons working under the guidance and supervision of a qualified electrician, in accordance with the electrotechnical regulations.</li> </ul>

- Wherever possible disconnect products from the power supply when carrying out commissioning, maintenance or repair work on them.
- Lock volt-free areas to prevent them being switched back on again by mistake.
- Label the connection terminals with external external voltage using a 'DANGER External voltage' sign.
- Route mains connections to products separately and fuse them with their own, clearly marked fuse.
- Fit an easily accessible disconnecting device in accordance with IEC 60950-1 outside the installation.
- Produce earthing as stated in local safety regulations.

### Mounting, installation, commissioning and maintenance

- If you require tools such as a ladder, these must be safe and must be intended for the work in hand.
- When starting the fire control panel ensure that unstable conditions cannot arise.
- Ensure that all points listed in the 'Testing the product operability' section below are observed.
- You may only set controls to normal function when the product operability has been completely tested and the system has been handed over to the customer.

	<b>⚠ WARNING</b>
	<p><b>Work carried out by personnel who are not qualified</b> Risk of explosion</p> <ul style="list-style-type: none"> <li>• Work in potentially explosive areas may only be carried out by qualified specialists or by specially instructed persons, in accordance with the national and international directives and regulations.</li> </ul>

- You must only mount, install, and test the devices if the atmosphere in the area is not at risk of explosion.

### Testing the product operability

- Prevent the remote transmission from triggering erroneously.
- If testing building installations or activating devices from third-party companies, you must collaborate with the people appointed.
- The activation of fire control installations for test purposes must not cause injury to anyone or damage to the building installations. The following instructions must be observed:
- Use the correct potential for activation; this is generally the potential of the building installation.
- Only check controls up to the interface (relay with blocking option).
- Make sure that only the controls to be tested are activated.
- Inform people before testing the alarm devices and allow for possible panic responses.
- Inform people about any noise or mist which may be produced.
- Before testing the remote transmission, inform the corresponding alarm and fault signal receiving stations.

### Modifications to the system design and the products

Modifications to the system and to individual products may lead to faults, malfunctioning and safety risks. Written confirmation must be obtained from Siemens and the corresponding safety bodies for modifications or additions. No changes may be made to devices with EC-type examination certificates.

### Modules and spare parts

- Components and spare parts must comply with the technical specifications defined by Siemens. Only use products specified or recommended by Siemens.
- Only use fuses with the specified fuse characteristics.
- Wrong battery types and improper battery changing lead to a risk of explosion. Only use the same battery type or an equivalent battery type recommended by Siemens.
- Batteries must be disposed of in an environmentally friendly manner. Observe national guidelines and regulations.

### Disregard of the safety regulations

Before they are delivered, Siemens products are tested to ensure they function correctly when used properly. Siemens disclaims all liability for damage or injuries caused by the incorrect application of the instructions or the disregard of danger warnings contained in the documentation. This applies in particular to the following damage:

- Personal injuries or damage to property caused by improper use and incorrect application
- Personal injuries or damage to property caused by disregarding safety instructions in the documentation or on the product
- Personal injury or damage to property caused by poor maintenance or lack of maintenance

## Disclaimer

We have checked that the content of this document matches the hardware and software described. Despite this, we cannot rule out deviations and cannot therefore assume liability for them matching completely. The details in this document are checked regularly and any corrections needed included in subsequent editions.





We are grateful for any suggestions for improvement.

## 2.3 Standards and directives complied with

A list of the standards and directives complied with is available from your Siemens contact.

## 2.4 Release Notes

Limitations to the configuration or use of devices in a fire detection installation with a particular firmware version are possible.

	 <b>WARNING</b>
	<p><b>Limited or non-existent fire detection</b></p> <p>Personal injury and damage to property in the event of a fire.</p> <ul style="list-style-type: none"> <li>• Read the 'Release Notes' before you plan and/or configure a fire detection installation.</li> <li>• Read the 'Release Notes' before you carry out a firmware update to a fire detection installation.</li> </ul>

	<b>NOTICE</b>
	<p><b>Incorrect planning and/or configuration</b></p> <p>Important standards and specifications are not satisfied. Fire detection installation is not accepted for commissioning. Additional expense resulting from necessary new planning and/or configuration.</p> <ul style="list-style-type: none"> <li>• Read the 'Release Notes' before you plan and/or configure a fire detection installation.</li> <li>• Read the 'Release Notes' before you carry out a firmware update to a fire detection installation.</li> </ul>

## 3 Structure and function

### 3.1 Overview

The manual call points are intended for use in places where a fire can be detected by people who can manually trigger an alarm.

The manual call point consists of a housing and a switching unit. It has the following features:

- Indirect activation
- Two-wire installation for all cable types
- Individual detector addressing
- Indication of the status (alarm, localization or test) by means of a dichromatic LED
- Communication via FDnet/C-NET
- Mounting on the FDnet-Ex/C-NET-Ex downstream of a line adapter (Ex) FDCL221-Ex
- Can be addressed on the FDnet-Ex/C-NET-Ex detector line

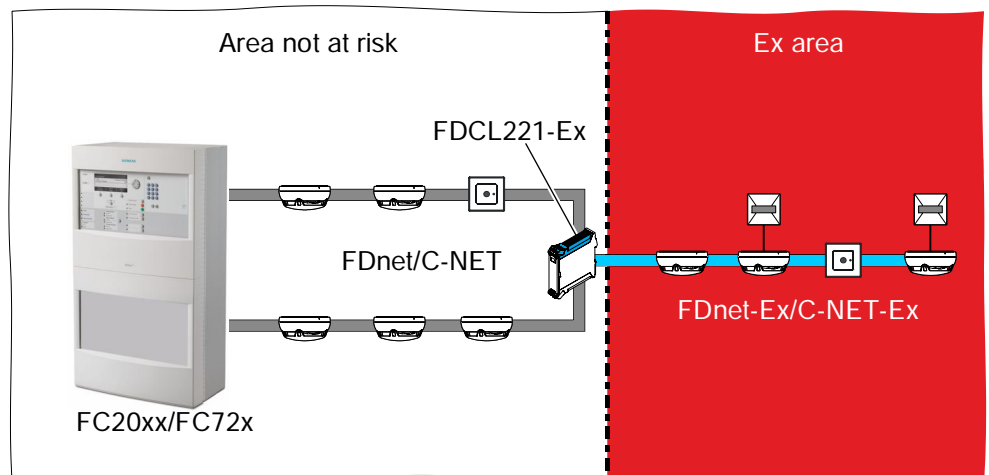

Use of a manual call point FDM223-Ex on the FDnet-Ex downstream of a line adapter (Ex) FDCL221-Ex

#### 3.1.1 Details for ordering

Type	Order no.	Designation
FDM223-Ex (complete)	S54329-F5-A1	Red housing with glass insert, Allen key, switching unit, 3 cable grippers (2-hole), and 'Not in use' sign

#### 3.1.2 Reference to technical manual

	<p>You will find this symbol on all devices designed for use in areas at risk of explosion. It indicates that you will find important information on using the device correctly in the technical manuals.</p> <p>Read and follow the instructions in the technical manual.</p>
--	--

### 3.1.3 Product version ES

The product version ES provides the technical status of a device in terms of software and hardware. The product version is provided as a two-digit number.

You will find the details of your device's product version:

- On the packaging label
- On the product label or the type plate

#### Product version on the packaging label

Details of the product version can be found directly on the packaging label in the barcode:

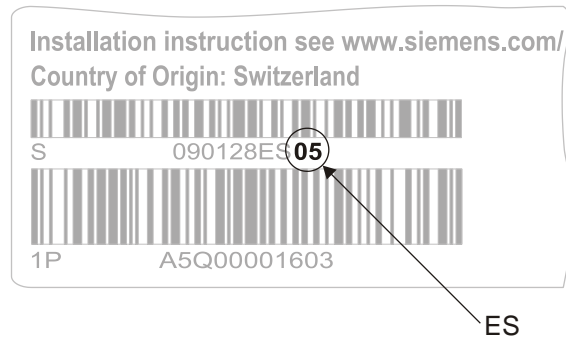

*Example of a packaging label with details of the product version*

#### Product version on the product label and the type plate

Details of the product version can be found after the device order number:

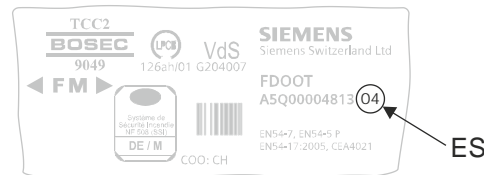

*Example of a product label with details of the product version*



Depending on the product and various approvals, the product labels may differ in terms of the information type and layout.

Look for your device's order number on the product label.

You will find the product version after the order number.

## 3.2 Setup

### 3.2.1 Manual call point FDM223-Ex

The FDM223-Ex manual call point triggers an alarm when the glass insert is pushed in and the alarm button is pressed (indirect activation). The alarm is immediately transmitted to the control panel.



To reset the manual call points after an alarm, a new glass insert must be inserted.

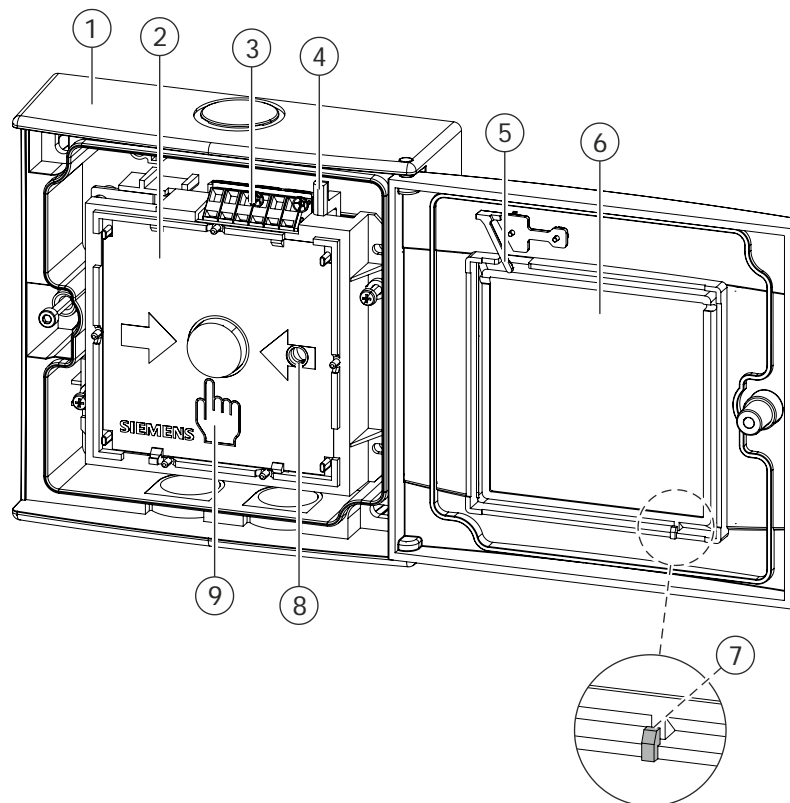

*Manual call point FDM223-Ex with opened door*

- |   |                           |   |                            |
|---|---------------------------|---|----------------------------|
| 1 | Back box                  | 6 | Glass insert               |
| 2 | Switching unit            | 7 | Guide for the glass insert |
| 3 | Spring clips              | 8 | Internal alarm indicator   |
| 4 | Stopping lever            | 9 | Alarm button               |
| 5 | Retainer for glass insert |   |                            |

### 3.2.2 Connections

The manual call point FDM223-Ex has six spring clips on the top of the switching unit; these are for the detector line and for connecting external alarm indicators.

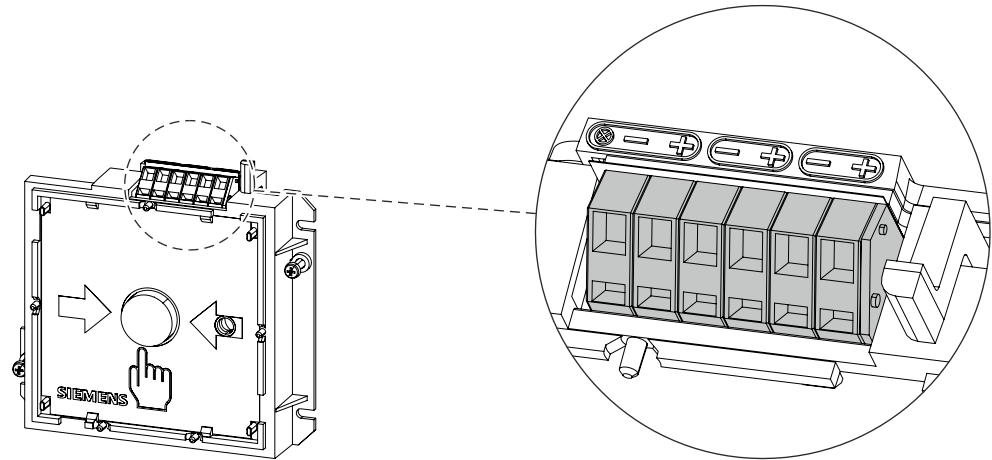

*Switching unit with spring clips*

### 3.2.3 Indication elements

A two-color LED is built into the switching unit as an internal alarm indicator.

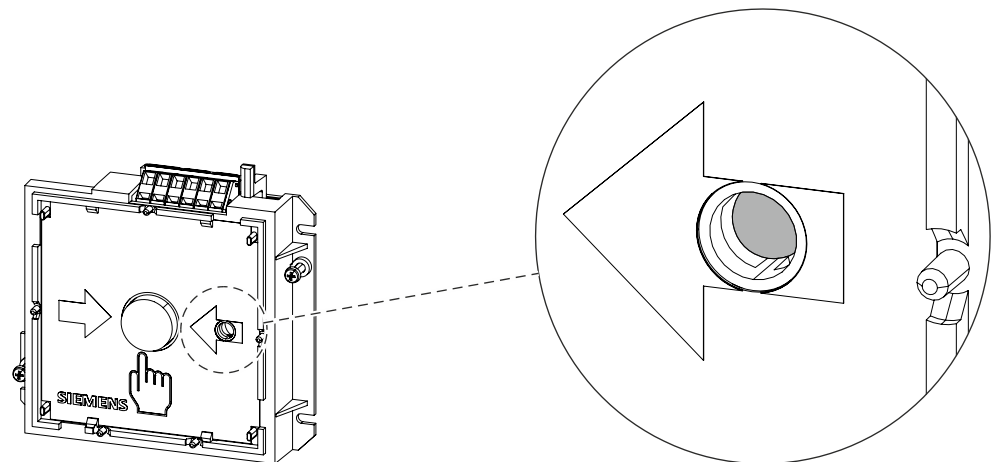

*Switching unit with alarm indicator*

#### See also

- Internal alarm indicator [→ 21]

## 3.3 Function

### 3.3.1 Danger levels

The manual call point can transmit the following danger levels to the control panel:

Danger level	Meaning
0	Normal state, no danger
3	Alarm

The evaluation of the danger level and the resulting measures (e.g. activation of remote transmission) are configured on the control panel.

### 3.3.2 Internal alarm indicator

The LED indicator of the alarm indicator has the following meanings:

LED indication	Meaning
Off	<ul style="list-style-type: none"> <li>● Normal condition</li> </ul>
Green Flashes once per second	<ul style="list-style-type: none"> <li>● Test mode is active</li> </ul>
Red Flashes once per second	<ul style="list-style-type: none"> <li>● Localization is active o r</li> <li>● Alarm is triggered</li> </ul>
Red and green alternating Flashes twice per second	<ul style="list-style-type: none"> <li>● Alarm is triggered/localization is active a n d</li> <li>● Test mode is active</li> </ul>

#### See also

 Indication elements [→ 20]

### 3.3.3 Test mode

A test mode must be set on the control panel to test the manual call points. When in test mode, alarms from the manual call points are not forwarded by the control panel.

### 3.3.4 Diagnosis levels

The manual call point monitors its operation largely autonomously.

The following diagnosis levels are derived from the different control measurements:

- Normal
- Replacement necessary
- Fault

When an error occurs which impairs the correct functionality of the device, a fault message is reported to the control panel.

### 3.3.5 Behavior in degraded mode

**For the FDnet/C-NET and a FDnet/C-NET connected to the , the following applies:**

When the main processor of the fire control panel fails, the control panel is in degraded mode operation. Depending on the control panel type, the fire control panel can continue to perform the most important alarming and signaling functions in degraded mode operation.

**Behavior of control panels that support degraded mode operation:**

Alarming is still ensured in degraded mode operation. However, in degraded mode only collective alarming is possible. This means that in the event of an alarm, it is possible to identify the FDnet/C-NET detector line but not the exact location of the detector triggering the alarm.

Degraded mode operation on the FDnet/C-NET is not supported in the same way by all control panels. The information in the 'List of compatibility' and in the corresponding control panel documentation must be taken into account during project planning.

### 3.3.6 Line tester

	<b>⚠ WARNING</b>
	<p><b>Using the line tester FDUL221 during commissioning</b></p> <p>Risk of explosion</p> <ul style="list-style-type: none"> <li>● Only operate the line tester FDUL221 in the area that is not at risk of explosion.</li> <li>● If peripheral devices on an FDnet-Ex/C-NET-Ex detector line are to be read into the line tester FDUL221, make sure there is a line adapter (Ex) FDCL221-Ex between the line tester and the peripheral devices.</li> </ul>

The line tester FDUL221, used in conjunction with the line adapter (Ex) FDCL221-Ex, can identify and localize the following faults in the FDnet/C-NET and FDnet-Ex/C-NET-Ex:

- Wiring error
- Open line
- Short-circuit

In addition, the line tester recognizes the devices connected to the FDnet/C-NET detector line and the FDnet-Ex/C-NET-Ex detector line.

You will find more information in document 008250.

#### See also

 [Applicable documents \[→ 8\]](#)

## 3.4 Accessories

### 3.4.1 Glass insert DMZ1196-AC

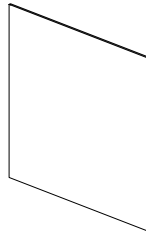

- For alarm activation and protection against soiling
- Order no.: BPZ:4942050001

### 3.4.2 Protective cover DMZ1197-AC

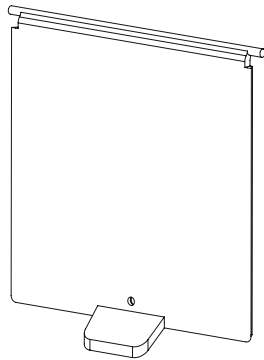

- For protection against unintended alarm activation
- Order no.: BPZ:5223550001

### 3.4.3 Cable gripper (2-hole)

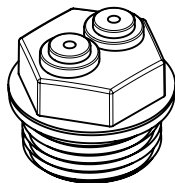

- For inserting two cables into one housing
- For cable diameters of up to 7.8 mm
- Male thread M20 x 1.5
- Order no.: A5Q00010055

### 3.4.4 M20 x 1.5 metal cable gland

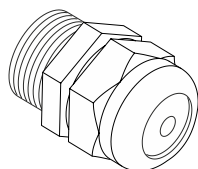

- For introducing a cable into the following devices:
  - Base attachment humid FDB293
  - Base attachment wet FDB295
  - Manual call point FDM223-Ex
- For cable diameters of 3.5...5.5 mm
- Temperature range: -40...+100 °C
- Allows for increased IP protection
- Order no.: A5Q00004478

### 3.4.5 Seal DMZ1197-AD

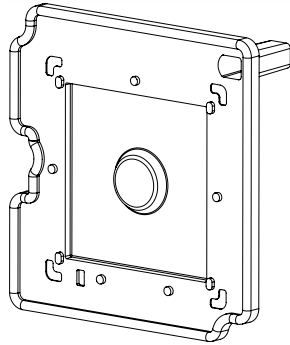

- For using the manual call point in areas where there is a risk of splash water
- Increases the IP protection category of the manual call point
- Order no.: BPZ:5470680001

### 3.4.6 Line adapter (Ex) FDCL221-Ex

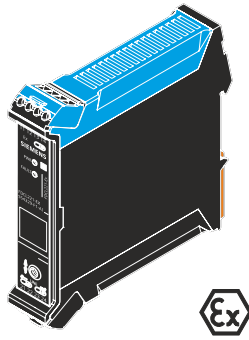

- For operating peripheral devices on the FDnet-Ex/C-NET-Ex in areas at risk of explosion
- Electrical isolation of detector lines in an area at risk of explosion from detector lines in an area not at risk of explosion
- Mounting on a U-rail TS35 or in a separate housing
- For details, see document A6V10333771
- Order no.: S54329-F4-A1

## 4 Planning

### 4.1 Compatibility

Compatible with control panels that support the FDnet-Ex/C-NET-Ex detector line. The table below shows the compatibility of the manual call point with various control panels:

Detector line	Control panel			
	FC20xx	FC72x	SIGMASYS	AlgoRex
FDnet-Ex	X	-	X <sup>1</sup>	X 1
C-NET-Ex	-	X	-	-

X = compatible

X<sup>1</sup> = compatible with line card (FDnet/C-NET)

- = not compatible

You will find details in the 'List of compatibility'.

#### See also

 Applicable documents [→ 8]

### 4.2 Fields of application

The manual call points are intended for use in places where a fire can be detected by people who can manually trigger an alarm.

### 4.3 Mounting site

The manual call points must be installed in easily accessible places at a height of 0.9...1.6 m on an even surface.



---

Observe the country-specific regulations for the exact mounting height!

---

## 5 Mounting/Installation



### WARNING

#### Electrostatic charging when installing devices in an area at risk of explosion

Risk of explosion

- Only install devices if the atmosphere in the mounting area is not at risk of explosion.
- Observe the relevant regulations and recommendations for installing devices in areas at risk of explosion.



In certain cases, peripheral devices approved according to Directive 94/9/EC (ATEX Directive) may only be put into operation in a way that ensures that internal components required for explosion protection purposes cannot be damaged without this being detected. Therefore, it is only permitted to operate FDnet-Ex/C-NET-Ex peripheral devices in conjunction with a line adapter (Ex) FDCL221-Ex.

## 5.1 Preparation



In the case of the manual call point FDM223-Ex, cables cannot be inserted through the back of the housing. Cables must enter through one of the cable entry openings provided in the housing.

1. Open the door with the Allen key supplied.
  2. **NOTICE! Keep the Allen key in a safe place.**
  3. Determine the cable entry opening(s) in the housing.
    - Pry open the openings for feeding though cables in the cable gripper.
    - Screw the cable gripper into the housing.
  4. Close cable entry openings that are not required using cable grippers.
- ⇒ The manual call point FDM223-Ex is now prepared for mounting.

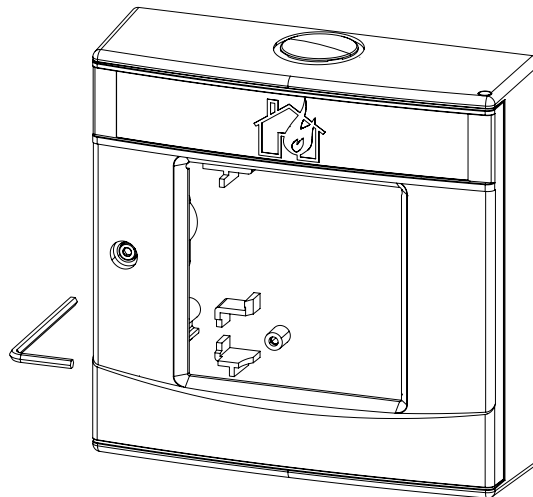

*Opening the door of the manual call point FDM223-Ex*

## 5.2 Mounting



Observe the country-specific regulations for the exact mounting height!

- ▷ The manual call point FDM223-Ex is prepared for installation. See the chapter 'Preparation [→ 27]'.
  1. Secure the housing at a height of 0.9...1.6 m on an even surface.
    - Only use the screw holes marked with arrows (see diagram below).
  2. Pull the cables into the housing through the openings in the cable gripper.
- ⇒ The manual call point FDM223-Ex is now prepared for electrical connection.

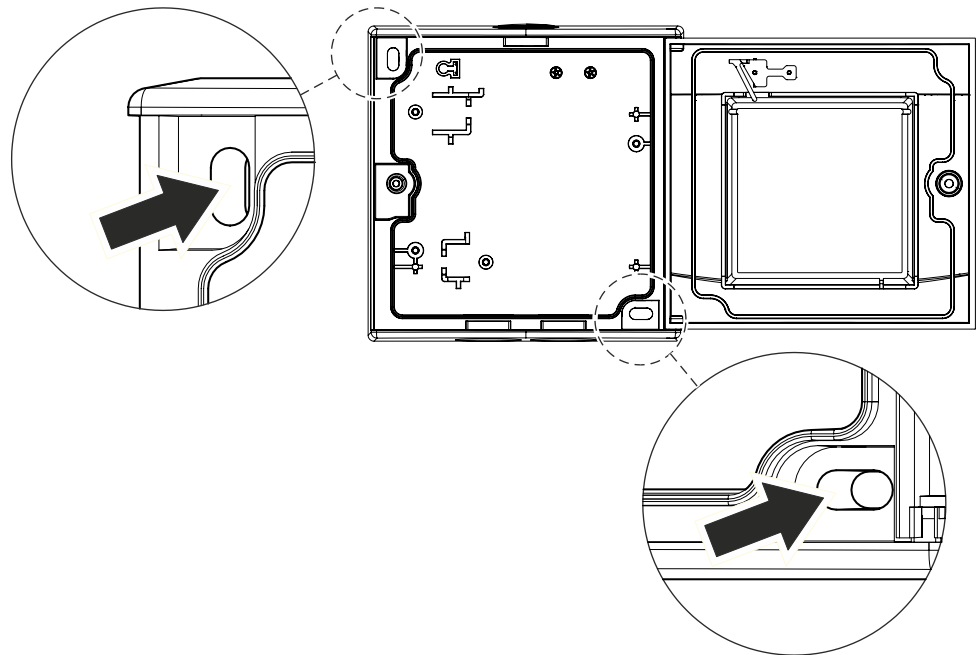

*Screw holes for manual call point FDM223-Ex*

## 5.3 Electrical connection

### Notes on work on electrical installations

	<b>⚠ WARNING</b>
	<p><b>Deactivating the manual call points prevents alarms from being forwarded.</b> The alarm is not triggered.</p> <ul style="list-style-type: none"> <li>• Mark deactivated manual call points or those which are not fully functional with the notice 'NOT IN USE'!</li> </ul>

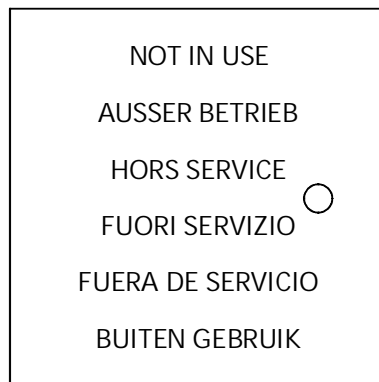

*'NOT IN USE' label*

	<b>⚠ WARNING</b>
	<p><b>Connecting cables in environments at risk of explosion</b> Risk of explosion</p> <ul style="list-style-type: none"> <li>• Only connect cables in an environment that is not at risk of explosion.</li> </ul>



If you are permanently decommissioning the equipment, observe the national regulations governing unused cables in areas at risk of explosion.



Note the positive and negative poles.  
Only connect one wire per terminal. This is the only way to ensure the connection is failure-free for the entire service life of the device.



We recommend that you do not use shielded cables for stub lines in areas at risk of explosion.

### Connection diagram

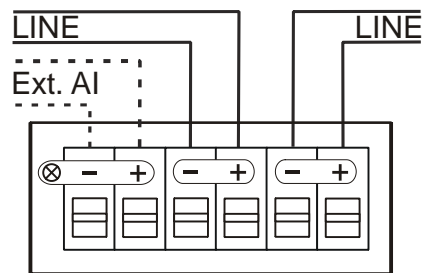

Connection diagram for manual call point FDM223-Ex

### Connecting the manual call point FDM223-Ex

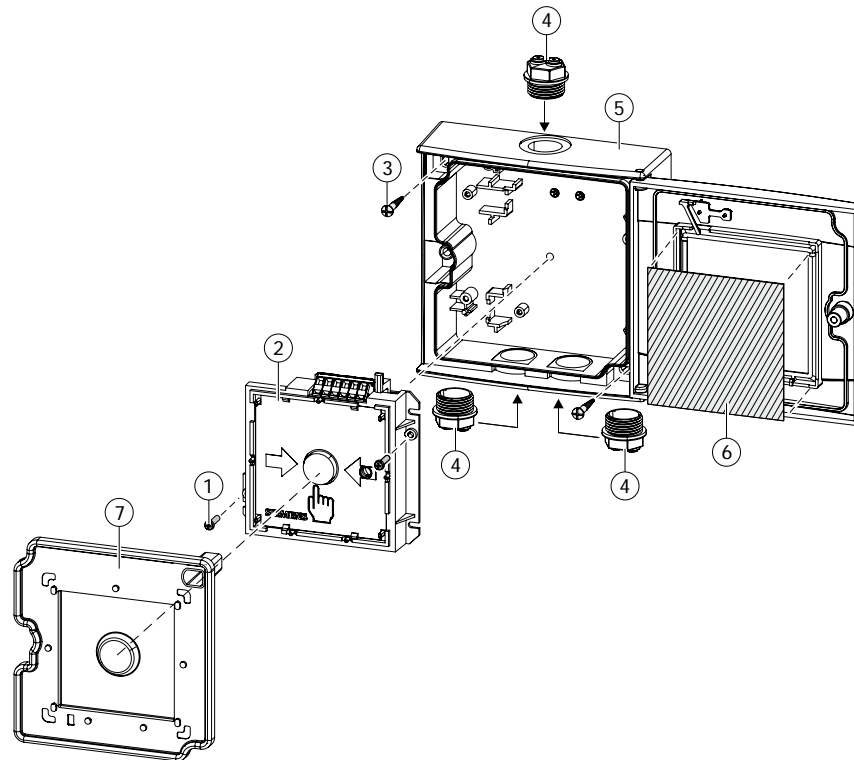

Installation of manual call point FDM223-Ex

- |   |                |   |                               |
|---|----------------|---|-------------------------------|
| 1 | Screw          | 5 | Housing                       |
| 2 | Switching unit | 6 | Glass insert                  |
| 3 | Screw          | 7 | Seal DMZ1197-AD (accessories) |
| 4 | Cable gripper  |   |                               |

	<b>⚠ WARNING</b>
	<p><b>Incorrect connection of detector line cable shielding</b></p> <p>Risk of explosion</p> <ul style="list-style-type: none"> <li>• Never connect detector line cable shieldings in an area at risk of explosion with detector line cable shieldings in an area not at risk of explosion</li> <li>• Never connect detector line cable shieldings for stub lines in an area at risk of explosion with detector line cable shieldings for other stub lines in an area at risk of explosion</li> </ul>

- ▷ The manual call point is prepared for electrical connection. See the chapters 'Preparation [→ 27]' and 'Mounting [→ 28]'.
1. Connect the feed line to the terminals in the switching unit (2), in accordance with the connection diagram.
  2. If using shielded cables:
    - **NOTICE! The shielding must not touch any external potentials.**
    - Connect the shielding for the detector line cable (LINE) to an auxiliary terminal in the housing.
    - Connect the shielding of the external alarm indicator cable with the positive pole of the external alarm indicator connection.
  3. **NOTICE! Avoid crushing the cables! Observe the feed line when inserting the switching unit (2) into the housing (5).**
  4. Insert the switching unit (2) into the housing (5) with the terminals facing upwards.
  5. Secure the switching unit (2) with two screws (1).
  6. Close the housing (5) with the door.
- ⇒ The manual call point is now electrically connected.

## 5.4 Installing the protective cover

If a protective cover (accessories) is used, proceed as follows:

- ▷ A compatible protective cover is available. See the chapter 'Accessories [→ 23]'.
  1. Open the door of the manual call point.
  2. Remove the glass insert. See the chapter 'Replacing the glass insert [→ 36]'.
    3. Thread the protective cover (1) through the opening in the door from the front, as shown in the diagram.
    4. Insert the pivot pins (2) for the protective cover (1) in the two recesses on the rear side of the door, as shown in the diagram.
    5. Install the glass insert. See the chapter 'Replacing the glass insert [→ 36]'.
      6. Close the door of the manual call point.

⇒ The protective cover is inserted.

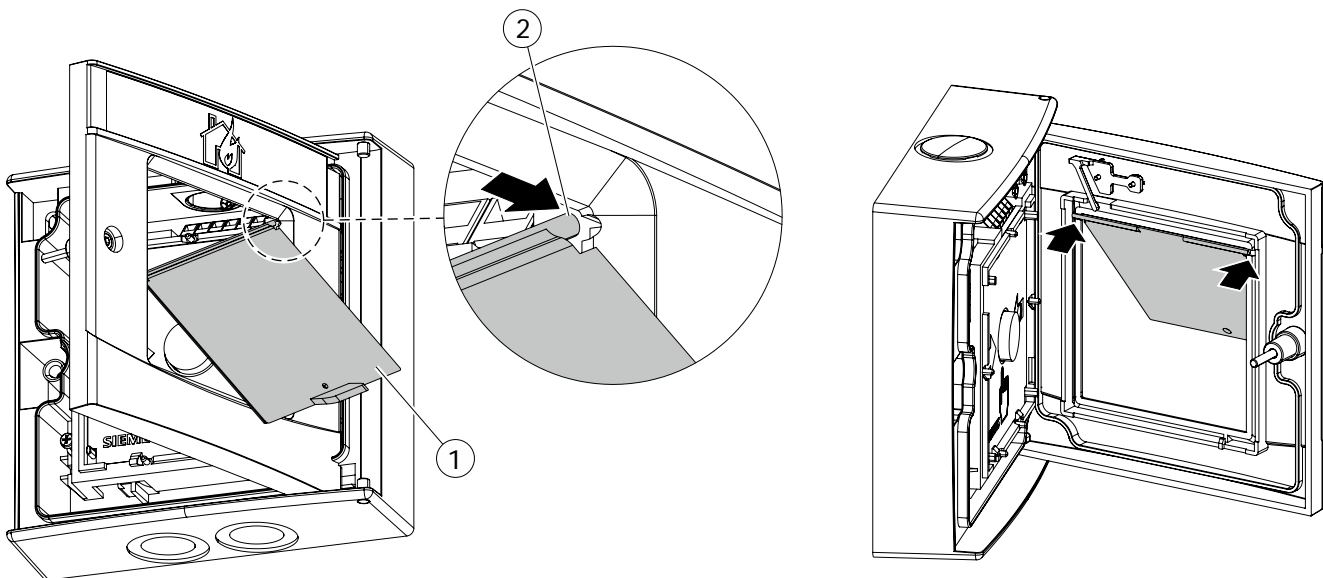

*Installing protective cover DMZ1197-AC on a manual call point FDM223-Ex*

- 1 Protective cover DMZ1197-AC
- 2 Pivot pin

## 6 Commissioning

The device is commissioned via the control panel. The exact procedure is described in the control panel documentation.

Conduct a performance check once commissioning is complete.

### 6.1 Localization and device testing

The manual call points have an internal alarm indicator. This alarm indicator may as well be activated from the control panel for localization and device testing.

The LED indicator of the alarm indicator has the following meanings:

LED indication	Meaning
Off	<ul style="list-style-type: none"> <li>● Normal condition</li> </ul>
Green Flashes once per second	<ul style="list-style-type: none"> <li>● Test mode is active</li> </ul>
Red Flashes once per second	<ul style="list-style-type: none"> <li>● Localization is active o r</li> <li>● Alarm is triggered</li> </ul>
Red and green alternating Flashes twice per second	<ul style="list-style-type: none"> <li>● Alarm is triggered/localization is active a n d</li> <li>● Test mode is active</li> </ul>

## 6.2 Checking function

- ▷ The manual call point is installed and electrically connected. See the chapter 'Electrical connection [→ 29]'.
1. Set the detector line to 'Test' on the control panel.
  2. Open the door of the manual call point with the Allen key.
  3. Press the alarm button.
    - ⇒ The alarm signal is transmitted.
  4. Check whether an alarm is displayed on the fire control panel.
  5. Push the black locking lever (1) in the upper right corner to the right until it clicks.
    - ⇒ The alarm button is now protruding by approx. 5 mm.
  6. Close the door of the manual call point.
    - ⇒ The manual call point is ready for operation again.
  7. Set the detector line to 'Normal operation' on the control panel.
- ⇒ The detector line is ready for operation again.

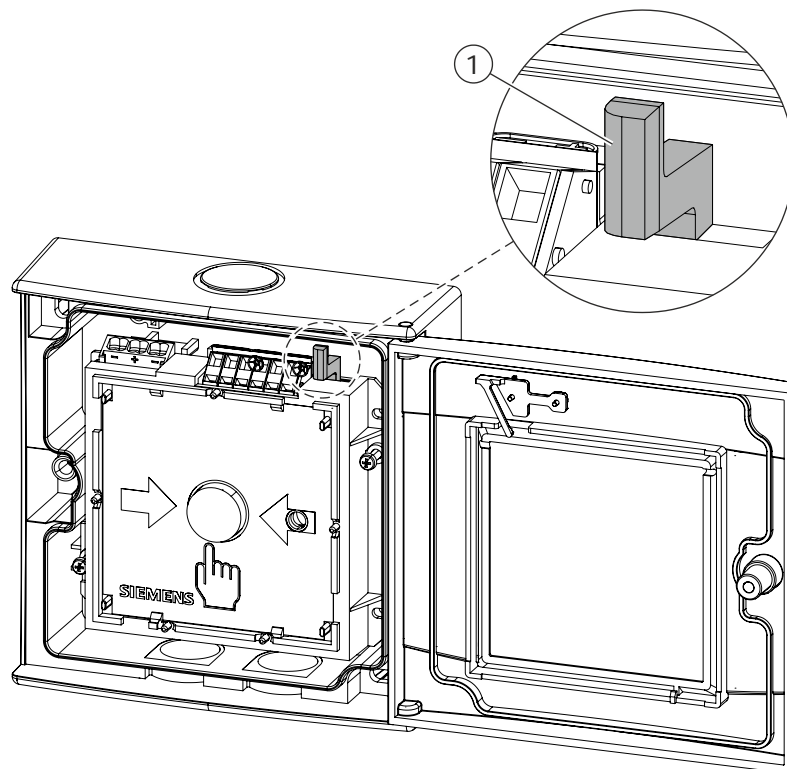

*Resetting manual call point FDM223-Ex*

- 1 Locking lever

## 7 Maintenance / troubleshooting

### 7.1 Resetting after an alarm

After an alarm is activated, the manual call point must be reset to a state in which it is ready for operation.

Reset the detector to a state of operational readiness as follows:

- ▷ The glass insert has been shattered and the alarm button is pressed.
  1. Open the door of the manual call point. See the chapter 'Preparation [→ 27]'.
    2. **CAUTION! Sharp remains of glass. Risk of cutting injuries when removing the remains of the glass insert. Remove the remains of the glass carefully.**
    3. Remove all the remains of the old glass insert.
    4. Insert a new glass insert. See the chapter 'Replacing the glass insert [→ 36]'.
      5. Push the black stopping lever in the upper right corner of the switching unit to the right until it clicks.
        - ⇒ The alarm button is now protruding by approx. 5 mm.
    6. Close the door of the manual call point.
    7. Carry out a performance check. See the chapter 'Checking function [→ 34]'.
      - ⇒ The manual call point is ready for operation again.

### 7.2 Status query

#### Status query on the control panel

Depending on the authorization level of the user and the control panel type, different actions can be performed from the control panel.

Observe the notices in the control panel documentation.

Document 009052 applies to control panels FC20xx.

Document A6V10210416 applies to control panels FC72x.

### 7.3 Performance check

The devices are automatically subjected to a performance check during the self-test. Nevertheless, it is necessary to check the devices on site at regular intervals.

#### Recommendation:

- Check the devices every year.
- Replace heavily soiled or damaged devices.

No other special maintenance work is necessary.

You will find more detailed information in the fire detection system documentation.

## 7.4 Replacing the glass insert

The glass insert is square-shaped and can be inserted in any direction.

Replace the glass insert as follows:

▷ The door of the manual call point is open. See the chapter 'Preparation [→ 27]'.  
1. Remove all the remains of the old glass insert.

2. Push the retainer (1) to the right.

3. Place the new glass insert under the guide (2).

4. Release the retainer (1).

5. Check the function of the manual call point.

6. Close the door.

⇒ The glass insert has been replaced.

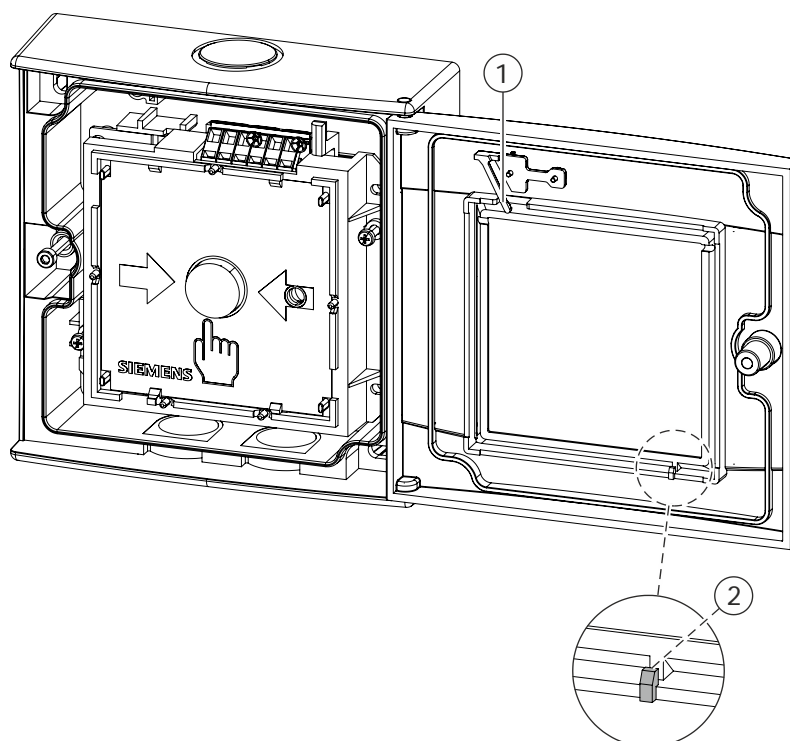

*Replacing the glass insert on manual call point FDM223-Ex*

1 Retainer

2 Guide

## 8 Specifications

### 8.1 Technical data

#### Device labeling

IECEX Scheme:	Ex ia IIC T4 Ga, Ta = -35...70 °C Ex ia IIIB T135 °C Da , Ta = -35...70 °C
Directive 94/9/EC: (ATEX Directive)	II 1 G Ex ia IIC T4 Ga, Ta = -35...70 °C II 1 D Ex ia IIIB T135 °C Da, Ta = -35...70 °C

<b>Ex-related connection data, intrinsically safe</b>	$U_i$	28 V
	$I_i$	92 mA
	$P_i$	650 mW
	$L_i$	Negligible
	$C_i$	0,2 nF
<b>Line to external alarm indicator</b>	$U_o$	14.2 V
	$I_o$	480 mA
	$P_o$	195 mW
	$L_o$	100 µH
	$C_o$	38 nF
	Only for connecting passive, external alarm indicators to negligibly small inductivities and capacities.	

You will find an explanation of the symbols in the chapter 'Technical terms, abbreviations, and formula symbols [→ 10]'.  
You will find information on approvals, CE marking, and the relevant EU directives for this device (these devices) in the following document(s); see 'Applicable documents' chapter:

- Document A6V10349347

#### Detector line

Operating voltage	DC 13...28 V
Operating current (quiescent)	Typ. 210 µA
Maximum current connection factor	1.25
Quiescent current connection factor	1.25
Address connection factor	1
Protocol	FDnet-Ex/C-NET-Ex
System compatibility	See 'List of compatibility'

<b>External alarm indicators</b>	Number of external alarm indicators that can be connected	Max. 1 external alarm indicator FDAI9x-Ex	
	Voltage	DC 9...14.2 V	
	Current	9...15 mA	
	Length of line	<ul style="list-style-type: none"> <li>● Max. 30 m with unshielded cables, or when the shielding is connected to the positive pole of the detector base</li> <li>● Max. 5 m, if the shielding is connected to earth</li> </ul>	
<b>Connections</b>	Flashing interval times:		
	● Bright	12 ms	
	● Dark	1 s	
	Detector line and external alarm indicators:		
	● Design	Spring clips	
	● Cable cross section	0.2...1.5 mm <sup>2</sup>	
	<b>Ambient conditions</b>	Operating temperature	-25...+70 °C
		Storage temperature	-35...+75 °C
		Air humidity	≤95 % rel.
		Protection categories (IEC 60529):	
● Manual call point		IP44	
● Manual call point with seal DMZ1197-AD (accessories)		IP66	
Environmental category according to EN 54-11		In buildings and outdoor areas	
Electromagnetic compatibility:			
● 1 MHz...1 GHz		50 V/m	
● 1 GHz...2 GHz		30 V/m	
<b>Mechanical data</b>	Design according to EN 54-11	Type B (indirect activation)	
	Dimensions (W x H x D)	134 x 134 x 43 mm	
	Housing material	Polyamide (PA)	
	Color	~RAL 3000 flame red	
	Weights:		
	● Housing	0.368 kg	
	● Switching unit	0.106 kg	
	● Glass insert	0.014 kg	
	● Protective cover	0.015 kg	
	<b>Standards</b>	European standards	EN 54-11
International standards		<ul style="list-style-type: none"> <li>● IEC/EN 60079-0</li> <li>● IEC/EN 60079-11</li> </ul>	
<b>Approvals</b>	IECEX/ATEX:	BVS 12 ATEX E 095 X	

## 8.2 Dimensions

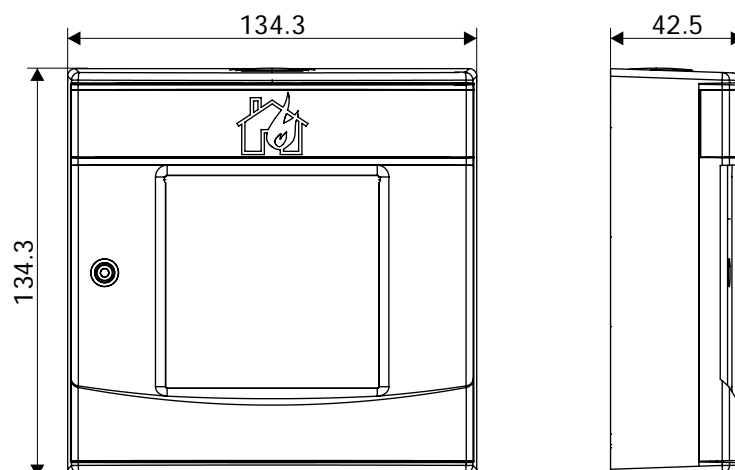

## 8.3 Master gauge for recesses

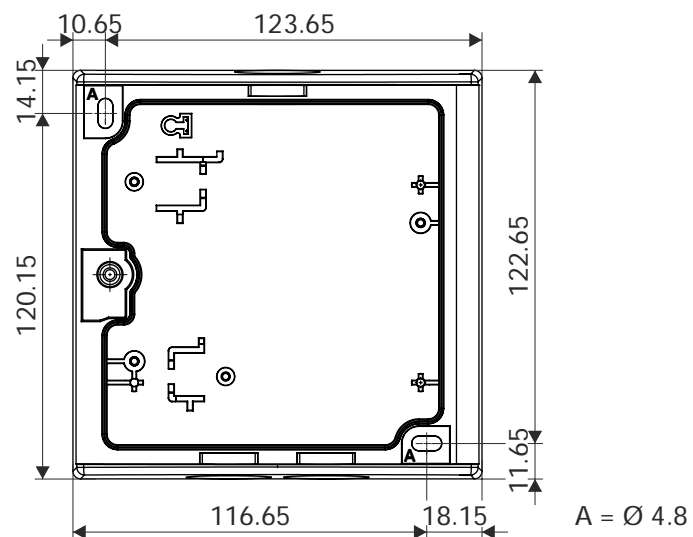

## 8.4 Environmental compatibility and disposal



This equipment is manufactured using materials and procedures which comply with current environmental protection standards as best as possible. More specifically, the following measures have been undertaken:

- Use of reusable materials
- Use of halogen-free plastics
- Electronic parts and synthetic materials can be separated

Larger plastic parts are labeled according to ISO 11469 and ISO 1043. The plastics can be separated and recycled on this basis.



Electronic parts and batteries must not be disposed of with domestic waste.

- Take electronic parts and batteries to local collection points or recycling centers.
- Contact local authorities for more information.
- Observe national requirements for disposing of electronic parts and batteries.

---

# Glossary

## Associated electrical equipment

Electrical equipment that contains both energy-limited and non-energy-limited circuits, and is structured in such a way that the non-energy-limited circuits cannot have a negative effect on any of the energy-limited circuits.

## Qualified person

A qualified person is someone who, as a result of their professional training and current occupational activities, has the knowledge required to test the work equipment. In some cases, the relevant national ordinances (such as the Ordinance on Industrial Safety and Health in Germany) make distinctions according to different qualification requirements; for example, they may place different requirements on a person's qualifications, skills, and experience.

# Index

- A**
- Alarm indicator, 21, 33
- Approvals, 37
- C**
- CE marking, 37
- Collective behavior
  - Degraded mode operation, 22
- Compatibility, 25
- Connection diagram, 30
- Connections
  - Spring clips, 20
- Control panel, 33
  - Status query, 35
- Customer Support Center
  - Service, 5
- D**
- Danger levels
  - Signals transmitted to the control panel, 21
- Degraded mode operation
  - Collective behavior, 22
  - Fire control panel failure, 22
- Device labeling, 6, 37
- Device type, 6
- Disposal, 40
- Documentation for fire detection system, 8
- Download
  - Document, 5
  - Download center, 5
- Download center
  - Link, 5
  - URL, 9
- E**
- Environmental compatibility, 40
- ES
  - Product version, 18
- EU directives, 37
- F**
- Fire control panel failure
  - Degraded mode operation, 22
- I**
- Installation in wet areas, 28
- Intended use, 6
- Internal alarm indicator, 21, 33
- Internet, 5
- L**
- List of compatibility, 22, 25
- M**
- Maintenance intervals, 35
- Manual call point
  - Test mode, 21
- Manufacturer, 6
- O**
- Operating temperature, 38
- Original language
  - Source language, 7
- P**
- Packaging label
  - Product version, 18
- Product label
  - Product version, 18
- R**
- Recycling, 40
- Resetting after an alarm, 35
- Restoring to a state of operational readiness, 35
- S**
- Service
  - Customer Support Center, 5
- Signals transmitted to the control panel
  - Danger levels, 21
- Source language, 7
- Spring clips
  - Connections, 20
- Status query
  - Control panel, 35

**T****Test mode**

Manual call point, 21

**Type plate**

Product version, 18

**Y**

**Year of construction**, 6

Issued by  
Siemens Switzerland Ltd  
Building Technologies Division  
International Headquarters  
Gubelstrasse 22  
CH-6301 Zug  
Tel. +41 41-724 24 24  
[www.siemens.com/buildingtechnologies](http://www.siemens.com/buildingtechnologies)

© Siemens Switzerland Ltd, 2012  
Technical specifications and availability subject to change without notice.